

UR 超高速大通孔径中空卡盘(3Jaw)



产品特点

大通孔楔型 3-Jaw 中空动力卡盘, 握持力强

主要技术

高刚性 BODY, 提高了耐久性
便于安装 Localator

握持力与转速的关系

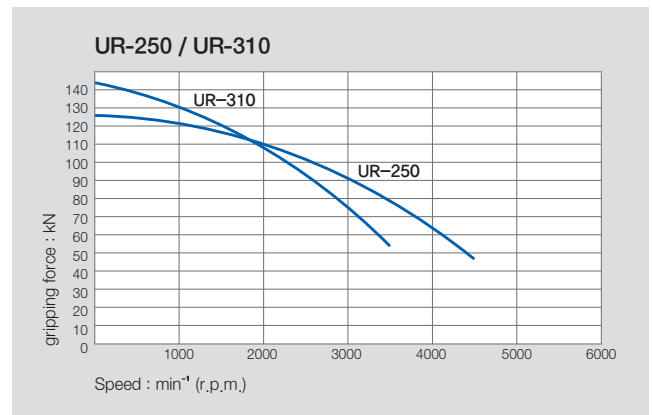
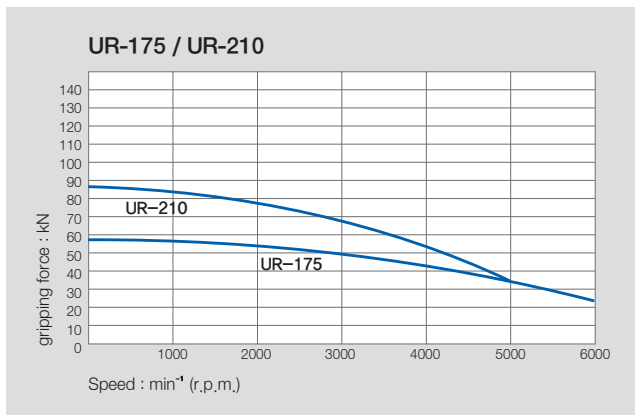

* Results reflect gripping force when using standard Samchully soft jaws. Variations in size of jaw and workpiece may decrease gripping force.

产品规格

	UR-175	UR-210	UR-250	UR-315
通径 [mm]	56	66	82	122
握持直径 Max. [mm]	175	210	254	315
握持直径 Min. [mm]	16	23	30	74
卡爪行程(直径) [mm]	6.4	8.0	10.0	10.6
柱塞行程 [mm]	14	17.5	22	23
允许的最大输入 [kN(kgf)]	25(2551)	38(3878)	50(5102)	50(5102)
允许的最大握持力 [kN(kgf)]	70(7143)	108(11020)	145(14796)	145(14796)
允许的最大最大转速 [min ⁻¹]	6000	5000	4000	3200
重量 [kg]	11	19.5	30	42
惯性力矩 [kg · m ²]	0.05	0.12	0.27	0.60
适用的 Cylinder	SD-15452	SD-17568	SD-18582	SD-30516
最大设定液压力 [MPa(kgf/cm ²)]	1.8(18.35)	2.5(25.49)	2.8(28.55)	1.4(14.27)

* 尺寸与规格可能不事先预告即作变更。

通孔径范围：Ø56~Ø122
夹持范围：Ø16.5~Ø315

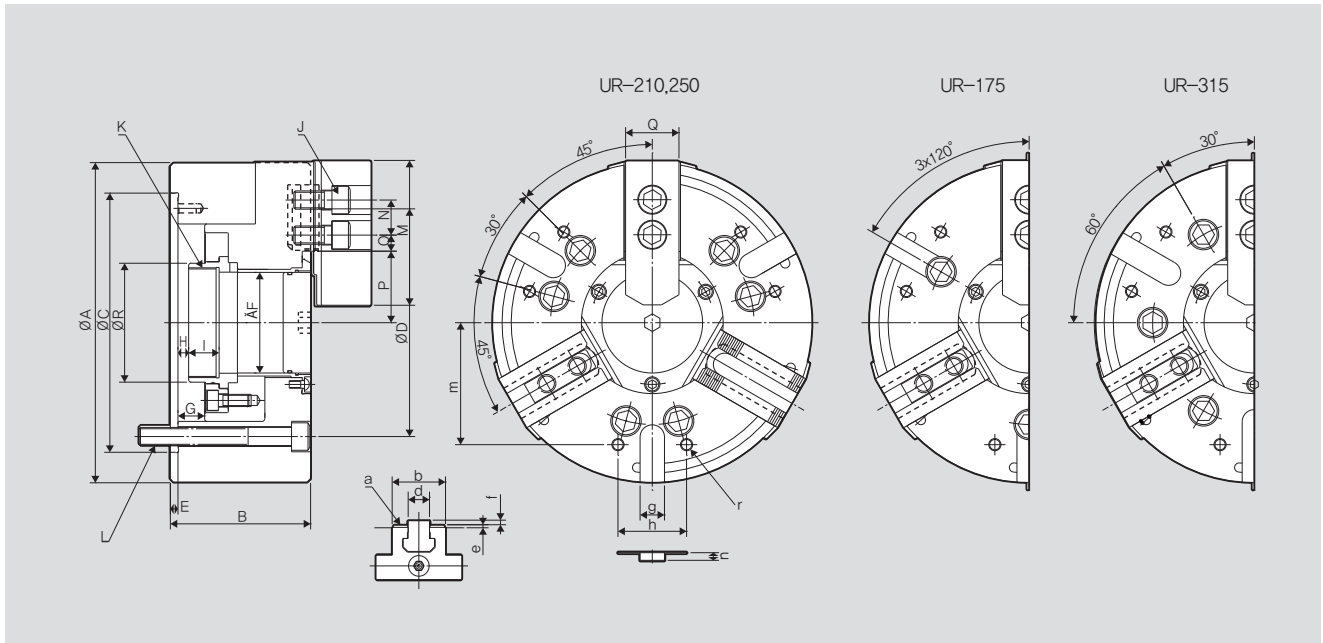

※ 为了保持卡盘寿命, 需要每天注入润滑油2次以上。

产品尺寸

	UR-175	UR-210	UR-250	UR-315
ΦA	175	210	254	315
B	81	92	103	115
ΦC (标准直径)	160	170	220	300
ΦD	133.4	133.4	171.4	235
E	5	5	5	5
F	56	66	82	122
G	14	17.5	22	23
H (max./min.)	4 / -10	7 / -10.5	13 / -9	19 / -4
I	18	20	20	23
J (UR-D/UR-M)	M10 / M10	M12 / M12	M12 / M12	M16 / M16
K (max)	M62x1.5P	M72x1.5P	M85x2.0P	M125x2.0P
L	M12	M12	M16	M20
M	70	95	110	125
N (UR-D/UR-M)	16.5 / 20	23 / 25	30 / 30	30 / 30
O (max./min.)	22 / 10	23 / 11	32 / 14	37 / 15
P (max./min.)	38/35	47/43	57/62	81/76
Q	31	35	40	50
R	71	78	92	143
a (UR-D/UR-M)	1/16"x90° / 1.5x60°	1/16"x90° / 1.5x60°	1/16"x90° / 1.5x60°	1/16"x90° / 1.5x60°
b	33	38	45	45
d (UR-D/UR-M)	12 / 14	17 / 14	21 / 16	21 / 21
e	3	3	4	4
f	2.5	2.5	3.5	3.5
g	16	16	16	20
h	36	45	60	60
m	65	80	102	100
n	5	5	5	5
r	M8	M8	M10	M10

※ Draw-nut 有标准件与未加工件。"K" 为 Draw nut 最大螺丝加工尺寸。

RELATED PRODUCT

